

Smart-AV

Smart Audio Video Integration

User Manual

AV Router



**High quality VGA RGBHV matrix that distributes signals directly.
Controlled via computer.**

Notice:

The information contained in this document is subject to change without notice. SmartAVI makes no warranty of any kind with regard to this material, including but not limited to, implied warranties of merchantability and fitness for any particular purpose.

SmartAVI will not be liable for errors contained herein or for incidental or consequential damages in connection with the furnishing, performance or use of this material.

No part of this document may be photocopied, reproduced or translated into another language without prior written consent from SmartAVI.

Table of Contents

Chapter 1: Introduction	4
What's in the Box	5
Overview	4
Applications	4
Chapter 2: Installation	5
Connecting the AVRouTer (Quick Start)	6
Connecting the AVRouTer (Detailed Instructions)	7
Video and Audio Inputs	7
Connecting the Communication Cable	7
System Power ON	10
Chapter 3: Software Installation and Operation	11
The Matrix Panel	12
The Button Panel	12
Macros	13
Chapter 4: Additional Hardware and Operation	14
Configuring more than one AVRouTer	14
Chapter 5: Technical Information	16
Chapter 6: Appendices	17
RS232 Commands	17
IR Commands	18
Connection Help Sheet	25

Chapter 1: Introduction

What's in the box:

AVRouter Package Contents		
QTY	Item	Part No.
1	AVRouter	AV * X*
1	Power Cord	CCPWR110V
1	RS232 to RS422 Adapter	SM-R232R422
1	RS422 to RJ45 Adapter	SM-RJ45RS422

Optional Accessories		
QTY	Item	Part No.
1	Video Cable (XVGA) Male to Male	CC-SVGAMM-06
1	Audio Cable (3.5mm to RCA Left and Right)	CC-MRAMM-06
1	Remote Control Unit	SM-RMT
1	IR Blaster	SM-16B
1	IR Emitter	SM-LED
1	IR Eye	SM-EYE
1	SLX-100 Receiver Unit	SLX-RX100
1	SXL-200 Receiver Unit	SLX-RX200

Overview

At times multiple AV signals need to be transferred to multiple nearby output monitors. The AV Router allows multiple VGA/audio inputs to be routed to multiple outputs simultaneously, by way of a direct connection into the router.

The AV Router is a high-quality switching matrix for VGA type signals. All signal formats are catered for including VGA, SVGA, XGA, RGBHV and sync on green (SOG) applications. For ease of installation, Standard VGA connectors (HD15 sockets) are used for the input as well as the output video signal. All that is required is a standard pin-to-pin VGA cable to connect to the signal source.

Stereo audio can also be routed to multiple outputs. The audio can either be routed independently or together with the video signal using the SmartControl software that is very easy to use.

Note: for maximum signal performance, use only high quality cable that has internal coaxial cable for each color.

The units contain a very high bandwidth routing matrix for the Red, Green and Blue video channels.

Applications

- Wall Displays
- Audio Visual Presentation
- Digital media
- Shopping centers
- Airports
- Security
- Dealer rooms
- Point of sale
- Control rooms
- Hotels

Chapter 2: Installation

Connecting the AVRRouter (Quick Start)

Warning: As a precaution, we recommend that you disconnect all power cords and make sure that all devices are turned off.

1. Plug in all external audio/video sources to the back of the AVRRouter. (Inputs)
2. Connect all external monitors and speakers to the back of the AVRRouter. (Outputs)
3. Connect RS232/RS422 adapter to the male serial port on your computer. Then connect the RS422/RJ45 adapter to that first adapter
4. Use CAT5 cable to connect the adapters (from computer) to the right (R) CAT5 terminal on the front panel of the AVRRouter unit.
5. Plug power cable into the AVRRouter unit.
6. Install SmartControl software.
7. Power on the AVRRouter.

Note: 2 adapters will be connected together. This is normal. RS232 to RS422 to RJ45.

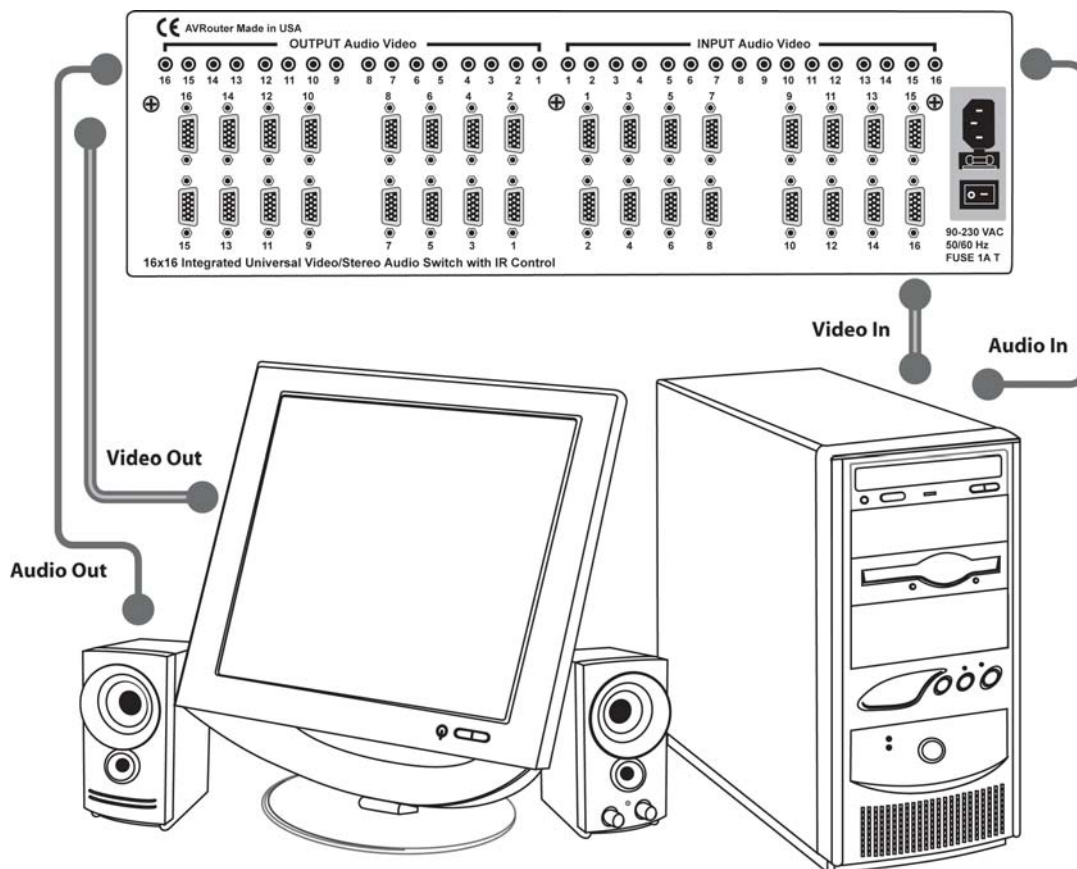

Connecting the AVRRouter (Detailed Instructions)

Video and Audio Inputs

The video input for the AVRRouter is a standard HD15 connection.

Connect all of the Input video sources to the back of the AVRRouter unit. The inputs are located on the right half of the rear panel.

Hint: You may want to label the input video connections so as not to lose track of where the signal is coming from. Later on when the software is installed you will be able to give each connection a name and the software will remember it for you. This way you can switch the video connections without having to look at the physical connections on the back of the unit. (You can also use the included page at the end of this manual in order to keep track of the connections as you make them.)

The audio inputs for the AVRRouter are standard 3.5 mm Stereo Miniplug connectors.

Connect all of the audio inputs to the back of the AVRRouter unit. The inputs are located on the right half of the rear panel. Many computer audio sources use this standard connection but there is other equipment such as receivers, and VCRs where a special adapter cable will be needed. Such as a 3.5mm miniplug to stereo RCA cable.

Make sure that the audio and video are coming from the same source and are plugged the same input number. For example, if the audio from one computer is connected to input 1, then the video should also be connected to input 1.

Video and Audio Outputs

The video and audio connections for the AVRRouter outputs are exactly the same. The only difference is that they are located on the left side of the back panel

Connect all of the external video monitors and corresponding speakers to the output connections located on the back of the AVRRouter unit.

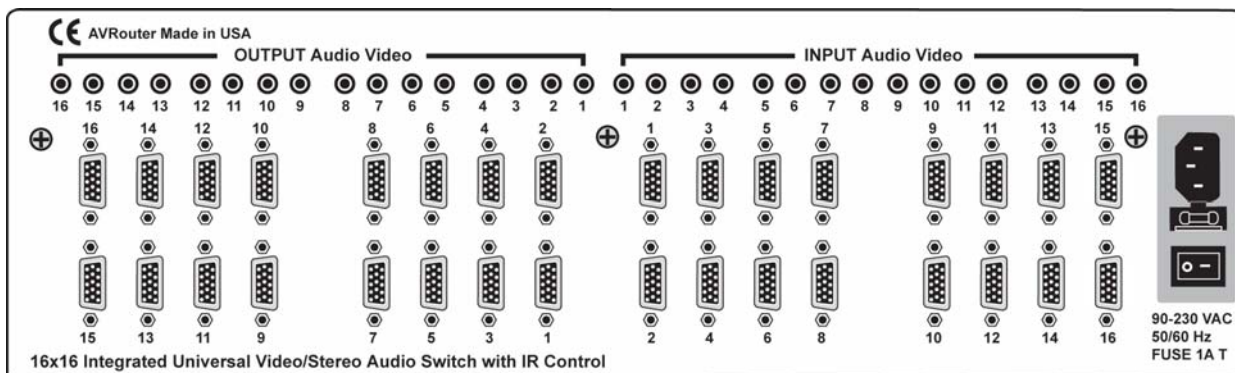

Chapter 2: Installation

Connecting the Communication Cable: RS422

Each unit can be controlled by a RS422 port connected via a RJ45 on the front of the chassis. Two connectors are provided for expansion, allowing a simple Cat 5 patch cable to link to additional units. The SmartControl software will be used to control the units.

There are 2 adapters:

- RS232 to RS422 adapter (Connects to the serial port on your computer)
 - RS422 to RJ45 adapter (connects to the other adapter as well as the AVRouter Unit)
1. Connect the RS232 to RS422 adapter into the control computer by connecting the female RS232 connector into the male RS232 connector of the PC. Turn the side screws so that it does not accidentally become disconnected
 2. Connect the RS422 to RJ45 adapter to the other adapter by connecting the female end into the male connector of the other adapter.
 3. Run a single UTP CAT5 cable from this connector to the front of the AVRouter unit.
 4. Connect CAT5 connector to the COMMS connector on the right.

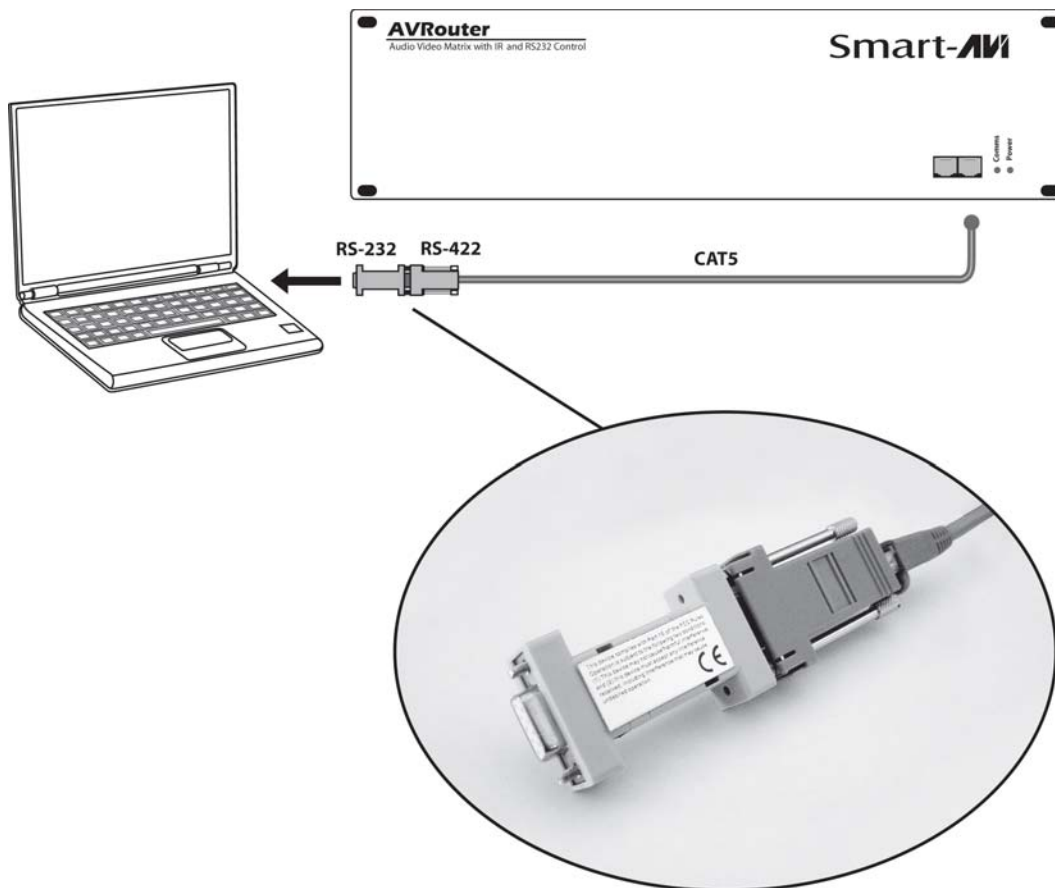

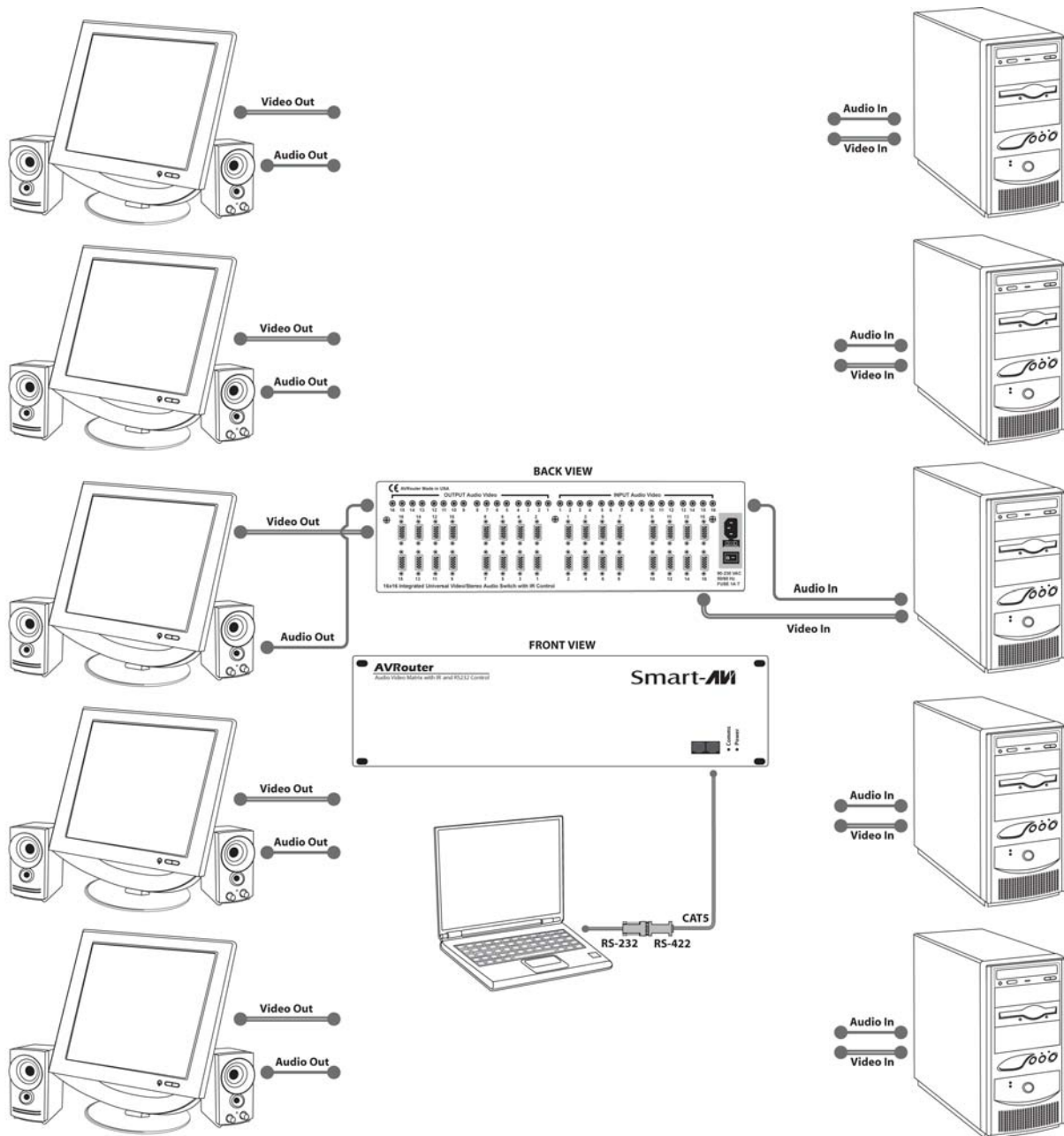

AVRouter connection diagram

System Power ON

You are now ready to turn on the system. Make sure that all connections are plugged in and all video monitors and speakers that you wish to use are connected.

1. Plug in the power cord to the back of the AVRouter unit. Connect this power cord to the wall.
2. Turn computer on and make sure that the boot up process has completed.
3. Observe to see if LEDs are lit. The AVRouter unit has two. One of those LEDs is for the power and the other is to indicate that the unit is functioning properly.
4. Power on all external monitors and speakers.

Chapter 3: Software Installation & Operation

Find the Installation CD that came with your AVRouTer unit. This CD has the SmartControl software that you will need in order to control the unit using a computer.

Insert the CD into your CD-ROM. On the CD you should see:

- SmartControl Installer.exe
- SmartControl Help File
- AVRouTer Manual in PDF format

Double click SmartControl.exe in order to initiate software installation. Click Install. After installation has completed, click CLOSE.

In order to use the software, click on the START button>Programs>SmartControl. There you should see a help file, the SmartControl launcher as well as a shortcut to uninstall SmartControl. Click on SmartControl in order to launch the software.

When the software starts you will see a screen like this.

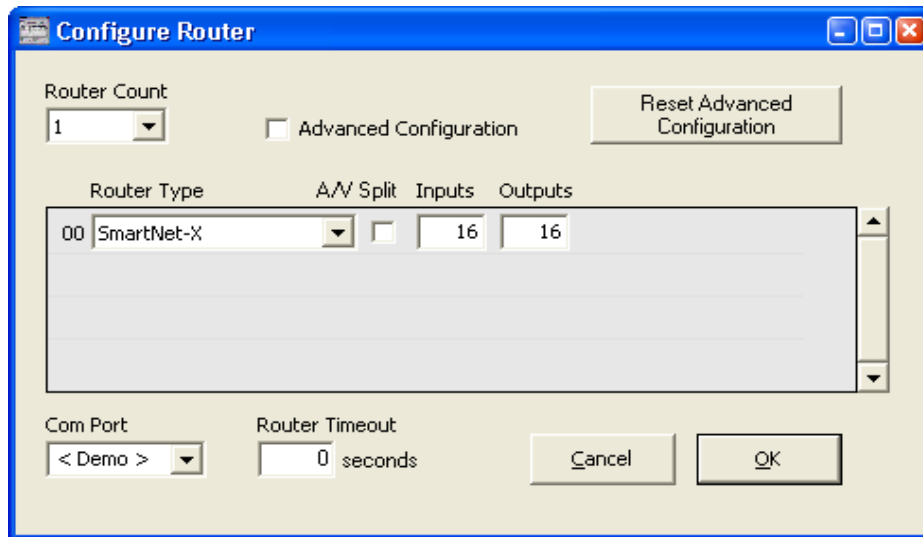

Advanced Configuration: If you have more than one Router installed you will want to check this box.

Router Type: Select SmartNet-X. This is not the actual model of the router but communication will still function properly if this is selected.

A/V Split: Check this box if you need to route audio and video independently, regardless from which source they originated from. Leave unchecked if you want audio and video signals from the same input to remain together.

For example, if you wanted to route different video feeds to different locations but wanted all of them to have the same audio, you should check the box.

Chapter 3: Software Installation & Operation

Inputs/Outputs: Enter the number of Inputs/Outputs your AVRouter has. For now we will assume that there are 16 inputs and 16 outputs.

Com Port: Select the appropriate com port that your computer is using to access the router.

Router Timeout: By default this is 0 meaning the computer acknowledges commands almost instantly. Sometimes a computer takes longer to respond. This setting should be left at 0. If you need to change it, it should be no higher than 0.2.

After you have entered in the necessary information click OK.

This will now take you to the Main Routing Window where you can route the different video/audio connections.

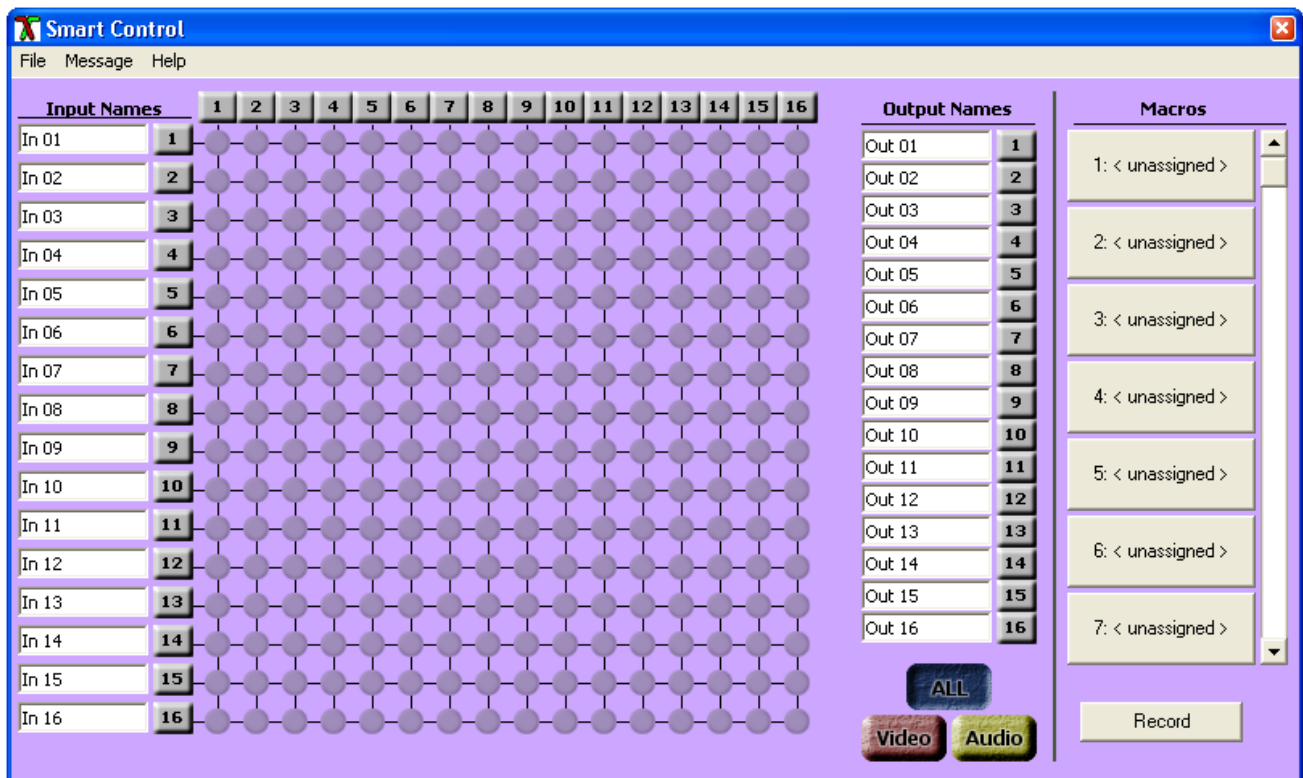

On this screen you will notice the input buttons running down the left side while the output buttons run across the top. They are each labeled 1 through 16.

Note: The three small colored buttons at the lower right labeled ALL, VIDEO, and AUDIO are not available if AV Split was not checked when you configured your router.

Chapter 3: Software Installation & Operation

The Main Routing Window enables you to control the router(s) connections by means of the matrix panel, the button panel, or with pre-recorded routes called macros.

Matrix Panel: This is probably the simplest way to route the connections. Simply click on the cross point itself. The input on the left will then be routed to the output above.

Note: Inputs can be routed to several different outputs, but each output can only have a single input at any one time. So you can have several connections horizontally but not vertically.



The Button Panel: These are the numbered buttons across the top and left sides. Click an output button on the top, and then click an input button on the left.

Options for using the Button Panel

Output Options:

To select multiple outputs next to each other, click on one output, then hold the shift key down and click the last output. When the input is clicked, it is routed to all selected outputs

To select multiple outputs individually, hold the control key down and click on any number of outputs. When the input is clicked, it is routed to all selected outputs.

Input Options:

To route an input to all the outputs at once, hold the control key down and click on an input.

To leave the outputs selected after the route is made, hold the shift key down and click on an input.

Macros: This section of the window is used to save and play back macros. Macros store a set sequence of routes.

To record a macro:

1. . Click on the Record button (last button shown above). A blinking “recording” message below this button will be displayed to indicate that all routes are being recorded.
2. . Select the desired cross points. (See Matrix Routing for details on making these routes.) There is no limit on the number of routes you may record.
3. If you click a macro button while in the record mode, the macro will be executed, and these routes will be added to the recording. This makes it possible to combine the routes of two or more macros into one bigger macro.
4. When finished, click the “Save Macro” button. You will be instructed to then click on one of the macro buttons. Doing this will save the recorded routes to that button.

To cancel saving the macro, click the “Cancel Save” button.

5. To play back a macro, simply click on one of the 50 macro buttons. Use the scrollbar to bring any of these into view.
6. The macros are automatically saved in the current configuration file. They are also saved when you select the File/Save Configuration... menu.

To save macros in a separate file for a special purpose, select the File/Save Macros...menu.

Chapter 4: Additional Hardware & Operation

Configuring more than one AVRouTer

Many times one AVRouTer is enough to suit ones needs, but at times it becomes necessary to have more connections. This is when it would be necessary to have multiple routers in order to have the opportunity to have more advanced connections.

There are different ways to connect the routers. We will assume there are two routers.

If you want to be able to control multiple routers, do the following:

The AVRouTer has two RJ45 connectors on the front of the unit. These connectors are used to control the units using a PC. The COMMS cable should already be connected to the right RJ45 connector on the primary unit.

Connect an additional CAT5 cable to the left port of the primary unit and run it to the right port on the second unit.

If you had more units you would continue this series connecting all of the units together.

Now all routers can be controlled by the computer. Remember that this configuration is used solely to control the units. This configuration is used only when you want to simulataneously switch two inputs to different pairs of outputs.. For example: you have four screens in one location and want to switch all of those inputsto four other screens in another location. A real life example would be a four screen video wall using 4 AVRouTer units. The four images must remain together.

As an example. Imagine having a two-screend video wall presentation. Each screen has a seperate input. If you want to switch both of these inputs into a separate set of screens, connect the AVRouters with the following configuration:

- 1 The video inputs must connect to two seperate routers. You can connect the left screen to one of the routers and the right screen into the other. Make sure that thy are both connected into the same input number.
- 2 Also make sure that the outputs are also seperated into the different routers. Make sure that all of the left screen inputs and outputs remain on the same router. Do the same for the right screen inputs and outputs.

On the following page you will see the setup configuration to connect four AVRouTer units and have them route a 4 screen presentation to multiple outputs.

Chapter 4: Additional Hardware & Operation

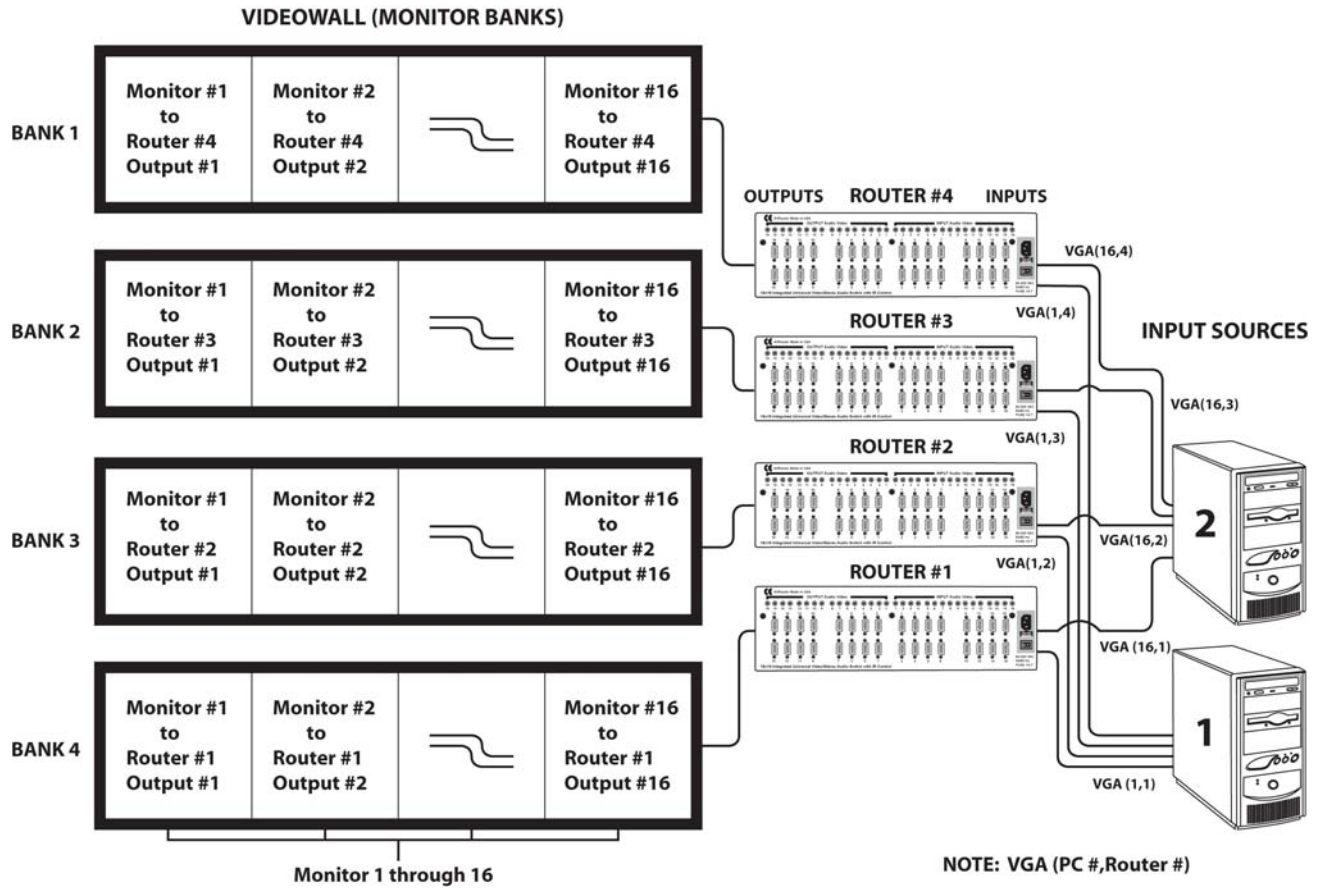

Chapter 5: Technical Information

MATRIX SPECIFICATIONS	
ITEM	DESCRIPTION
Video	
Bandwidth	200MHz
Input Signal Level	1Volt pk-pk into 75R
Output Impedance	100 Ohms
Input Impedance	75R Ohms
Connector	HD15 socket
Format	VGA/SVGA/XGA/RGBHV/RGsb/CVBS/YC/YUV/-RGBS
Syncs	TTL5VDC
Bandwidth	Horizontal Sync up to 85KHz
Resolution	640x480, 600x800, 1024x768, 280x1024, 1600x1200
Audio	
Signal	15KHz 0dB unbalanced 10000ohms impedance
Connector	3.5mm Stereo Jack (Input and Output)
Frequency Response	20 Hz to 20 kHz, +/-0.5 dB
Power	
Voltage	90-230V IEC 1A A/S 50/60 Hz
Physical	
Weight	4kg (8.8lbs)
Dimension (HxWxD)	133x441x287mm (5.2x17 ^{3/8} x11.3) *Front of unit is 482mm or 19in.

Chapter 6: Appendices

Although the following communication protocol has been specifically written for the SmartNet-X unit from SmartAVI, it is accurate for the AVRouTer and other units from SmartAVI.

1.0 Document Conventions

Any numbers preceded by '0x' are hexadecimal. (base 16)

All data byte string listed in examples are in hexadecimal. (base 16)

2.0 Comms Ports Settings.

The Host Controller Serial Port should be configured as detailed in the table below

Baud Rate	9600
Start Bits	1
Data Bits	8
Parity	None
Stop Bits	1

3.0 RS232/422 converter.

The Frame control interface uses RS422. A full duplex 5 wire balanced communications standard that allows communications to be multi-dropped to more than one Frame.

Since PC's only come with RS232 ports a small converter is required to convert the RS232 signals to RS422.

If you purchased any of the SmartControl software options you will have received a suitable converter and cable.

In the event that you wish to purchase your own converter and/or make your own comms cable please see Appendix A at the rear of this document for more information.

4.0 Connecting up

4.1. Plug the RS232 end of the RS232 to RS422 converter directly onto the selected comms port on the rear of your computer.

4.2. Plug the comms cable (D9 end) onto the end of the RS422 end of the RS232/RS422 converter.

4.3. Plug the RJ45 end of the comms cable into the IN port on the front of the SmartNet-X or SmartNet-V.

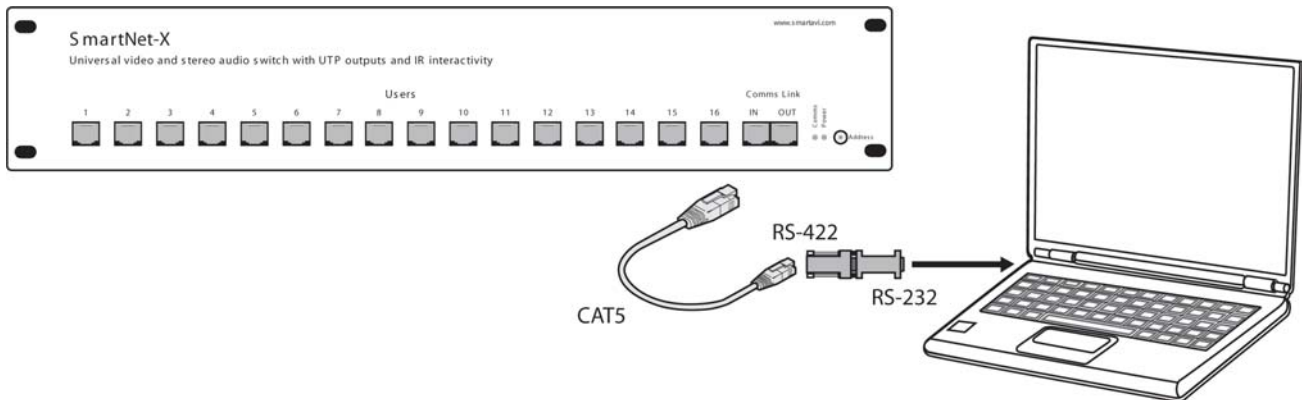

5.0 SmartNet-X Frame Switches

The communications port on the SmartNet-X allows for multiple chassis to be connected together.

Chapter 6: Communication Protocol

This is achieved by creating a loop between chassis using the comms IN and OUT ports on the front of the chassis. i.e.

Address	Hex Switch Setting
0	0
1	1
2	2
3	3
4	4
5	5
6	6
7	7
8	8
9	9
10	A
11	B
12	C
13	D
14	E
15	F

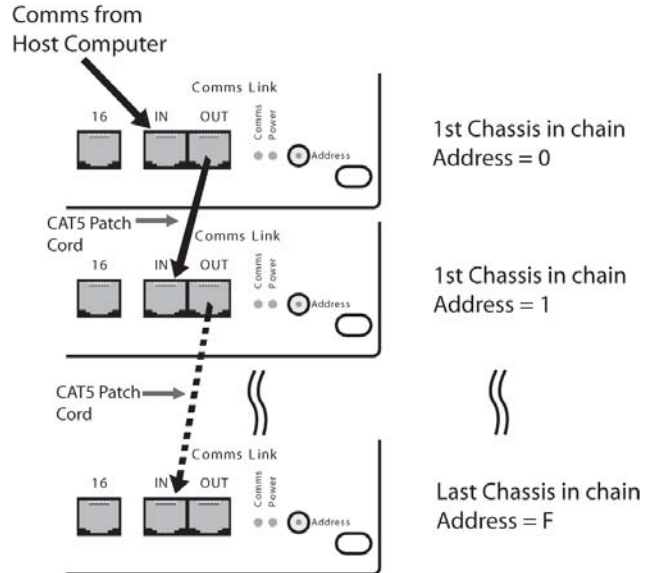

In order to ensure good communications it is essential that the Hex address switch on the front of the SmartNet-X is set correctly. The hex switch can be adjusted using a small flat blade screwdriver.

An incorrect setting or having more than one chassis set to the same address will result in comms errors.

6.0 Packet Structure

The general form of packets sent to the SmartNet-X switches are detailed below;

<Header Byte 0><Header Byte 1><Frame Address><Reserved><CMD><DATA BYTES><BCC>

Where ;

- <Header Byte 0>** Always 0xBE
- <Header Byte 1>** Always 0xEF
- <Address>** Frame address. Set by Hex switch on front of unit.
- <Reserved>** Reserved for future use (Always 0x00)
- <CMD>** Command byte – Determines the number of bytes in DATA BYTES
- <DATA BYTES>** Number of bytes for associated CMD
- <BCC>** XOR of all bytes in the string up to but not including BCC

On receipt of a valid data packet the SmartNet-X will either respond with an ACK (0x06) or a valid packet containing the requested data.

7.0 Implemented Commands @ 18/11/2003

Note: Commas shown in example byte strings below are not transmitted from the serial port they have only been added only to aid legibility.

7.1 Set Crosspoint Command : CMD = 0x00

Sets specified switch output or Destination to the specified input or Source.

Send: <0xBE><0xEF><Address><0x00><0x00><Source><Destination><BCC>

Chapter 6: Communication Protocol

Set Audio Only Crosspoint

Cmd = 4

Databytes = destination, source

i.e. to switch audio on output 3 to input 4

CMD = 3

Databytes = 3,4

Mute Video on specified output

Cmd = 5

Databytes = Destination, State (0=off, 1 = on)

i.e. to turn video off on output 3

CMD=5

Databytes = 3,0

i.e. to turn video on on output 3

Mute Audio on specified output

Cmd = 6

Databytes = Destination, State (0=off, 1 = on)

i.e. to turn audio off on output 3

CMD=6

Databytes = 3,0

i.e. to turn video on on output 3

CMD=6

Databytes = 3,1

Split Crosspoints - Video and Audio Differently

Cmd = 7

Not specified yet but will exist

Get Current Status

CMD 8 = current Status all

Databytes = Destination. (1-16 = specific output, 0xff = all)

i.e. to read the status of output 3 send;

CMD = 8

Databyte = 3

i.e. to read the status of all outputs

CMD=8

Databytes = 0xff

Unit will return Valid PSU as above where databytes is;

a single byte indicating currently selected source if specific destination was requested

or a string of 16 bytes indicating currently selected source for each destination starting with destination 1.

Chapter 6: Communication Protocol

The command to make the end of CAT5 line receiver (SLRX-RX300) switch between its local and remote sources is as follows;

<0xBE><0xEF><Frame Address><Reserved><CMD><DATA BYTES><BCC>

Where;

<0xBE> always 0xBE

<0xEF> always 0xEF

<Frame Address> Frame address. Set by Hex switch on unit or position in Rack frame.

<RESERVED> always 0x00

<CMD> 50 (0x32)

<DATABYTES> is Two bytes **<DESTINATION><SOURCE>** 0L = Receiver LOCAL Video/Audio, 1 = Receiver REMOTE Video/Audio

<BCC>

So if switching the Receiver on output 3 of Frame 2 to its local source send

<0xBE><0xEF><0x02><0x00><0x32><0x02><x00><0x63>

Get System Information

Cmd = 0xff

Databytes = NULL (none)

Unit will return a valid PSU as detailed above where Databytes are as follows

<product type>, <switch configuration> , <version>

Where Product Type =

1 Byte;

0 = SmartNet V

1 = SmartNet X

3 = SLX-TX550

4 = SLX-RX300

Where Switch configuration =

2 Bytes;

<inputs><outputs>

Where Version =

3 bytes

<Version><issue><release>

Appendix A: RS232/422 Converter and Comms Cable

RS232/RS422 Converter

A suitable RS232/RS422 product can be purchased from **KK Systems** in Brighton, East

Chapter 6: Communication Protocol

Comms Cable

DB9 cable ended plug	Function	UTP Wire Colours (RJ45)
1	-	-
2	RX-(A)	Orange
3	TX+(B)	White & Brown
4	0V	Blue
5	-	-
6	0V	Green
7	RX+(B)	White & Orange
8	TX-(A)	Brown
9	-	-

You will also require a cable that sits between the RS422 port of the K2 converter and the Frame. It should be wired as shown below. (Tip: Cut the end off a CAT5 Patch lead and attach a DB9 Plug)

Appendix B: On Screen Display Message Processing Rules. Available on SmartNet-V only

Due to the limitations of both the On Screen Display and the amount of available non-volatile memory in the SmartNet it is necessary for the Host system to perform some pre-processing of the message to be displayed.

The message string needs to be parsed character by character and the values translated according to the table below.

Characters	Translation Rule	Comment
"0" Through "9"	Chr\$(Asc(sChar) - 48)	Subtract 48 from ASCII value of character
"A" Through "Z"	Chr\$(Asc(sChar) - 53)	Subtract 53 from ASCII value of character
"a" Through "z"	Chr\$(Asc(sChar) - 55)	Subtract 55 from ASCII value of character
":"	Chr\$(&H27)	Substitute the character ":" for ASCII value 0x27
" " (space)	Chr\$(&H0b)	Substitute the character " " for ASCII value 0x0b
":"	Chr\$(&H26)	Substitute the character ":" for ASCII value 0x26
"/"	Chr\$(&H28)	Substitute the character "/" for ASCII value 0x28
""(Apostrophe)	Chr\$(&H29)	Substitute the character "" for ASCII value 0x29
":"	Chr\$(&H0A)	Substitute the character ":" for ASCII value 0x0a
"?"	Chr\$(&H70)	Substitute the character "?" for ASCII value 0x70
**	Chr\$(&H5F)	Substitute the character "*" for ASCII value 0x5f
"="	Chr\$(&H78)	Substitute the character "=" for ASCII value 0x78
">"	Chr\$(&H7A)	Substitute the character ">" for ASCII value 0x78
"<"	Chr\$(&H7B)	Substitute the character "<" for ASCII value 0x7b
"("	Chr\$(&H61)	Substitute the character "(" for ASCII value 0x61
")"	Chr\$(&H62)	Substitute the character ")" for ASCII value 0x62

Please see the following page for a working example of these rules in the form of a Visual BASIC function.

Chapter 6: Communication Protocol

Appendix B: Continued..... (Sample Translation routine in Visual BASIC)

Function LookUpOSDString(sTextMessage As String) As String

' Look up chars and translate to message for OSD

Dim iLoop As Integer

Dim sNewMess As String

Dim sChar As String

sNewMess = Space\$(MAX_SCREEN_CHAR)

For iLoop = 1 To Len(sTextMessage)

sChar = Mid\$(sTextMessage, iLoop, 1)

Select Case sChar

Case "0" To "9"

Mid\$(sNewMess, iLoop, 1) = Chr\$(Asc(sChar) - 48)

Case "A" To "Z"

Mid\$(sNewMess, iLoop, 1) = Chr\$(Asc(sChar) - 53)

Case "a" To "z"

Mid\$(sNewMess, iLoop, 1) = Chr\$(Asc(sChar) - 55)

Case "."

Mid\$(sNewMess, iLoop, 1) = Chr\$(&H27)

Case " "

Mid\$(sNewMess, iLoop, 1) = Chr\$(&HB)

Case ":"

Mid\$(sNewMess, iLoop, 1) = Chr\$(&H26)

Case "/"

Mid\$(sNewMess, iLoop, 1) = Chr\$(&H28)

Case ""

Mid\$(sNewMess, iLoop, 1) = Chr\$(&H29)

Case "-"

Mid\$(sNewMess, iLoop, 1) = Chr\$(&HA)

Case "?"

Mid\$(sNewMess, iLoop, 1) = Chr\$(&H70)

Case "*"

Mid\$(sNewMess, iLoop, 1) = Chr\$(&H5F)

Case "="

Mid\$(sNewMess, iLoop, 1) = Chr\$(&H78)

Case ">"

Mid\$(sNewMess, iLoop, 1) = Chr\$(&H7A)

Case "<"

Mid\$(sNewMess, iLoop, 1) = Chr\$(&H7B)

Case "("

Mid\$(sNewMess, iLoop, 1) = Chr\$(&H61)

Case ")"

Mid\$(sNewMess, iLoop, 1) = Chr\$(&H62)

Case Else

Mid\$(sNewMess, iLoop, 1) = Chr\$(&HB)

End Select

Next iLoop

LookUpOSDString = sNewMess

End Function

Limited Warranty Statement

A. Extent of limited warranty

1. SmartAVI Technologies, Inc. warrants to the end-user customers that the SmartAVI product specified above will be free from defects in materials and workmanship for the duration of 1 year, which duration begins on the date of purchase by the customer. Customer is responsible for maintaining proof of date of purchase.
2. SmartAVI limited warranty covers only those defects which arise as a result of normal use of the product, and do not apply to any:
 - a. Improper or inadequate maintenance or modifications
 - b. Operations outside product specifications
 - c. Mechanical abuse and exposure to severe conditions
3. If SmartAVI receives, during applicable warranty period, a notice of defect, SmartAVI will at its discretion replace or repair defective product . If SmartAVI is unable to replace or repair defective product covered by the SmartAVI warranty within reasonable period of time, SmartAVI shall refund the cost of the product.
4. SmartAVI shall have no obligation to repair, replace or refund unit until customer returns defective product to SmartAVI.
5. Any replacement product could be new or like new, provided that it has functionality at least equal to that of the product being replaced.
6. SmartAVI limited warranty is valid in any country where the covered product is distributed by SmartAVI.

B. Limitations of warranty

TO THE EXTENT ALLOWED BY LOCAL LAW , NEITHER SMARTAVI NOR ITS THIRD PARTY SUPPLIERS MAKE ANY OTHER WARRANTY OR CONDITION OF ANY KIND WHETHER EXPRESSED OR IMPLIED , WITH RESPECT TO THE SMARTAVI PRODUCT , AND SPECIFICALLY DISCLAIM IMPLIED WARRANTIES OR CONDITIONS OF MERCHANTABILITY, SATISFACTORY QUALITY , AND FITNESS FOR A PARTICULAR PURPOSE

C. Limitations of liability

To the extent allowed by local law the remedies provided in this warranty statement are the customers sole and exclusive remedies

TO THE EXTENT ALLOWED BY LOCAL LAW , EXCEPT FOR THE OBLIGATIONS SPECIFICALLY SET FORTH IN THIS WARRANTY STATEMENT , IN NO EVENT WILL SMARTAVI OR ITS THIRD PARTY SUPPLIERS BE LIABLE FOR DIRECT, INDIRECT, SPECIAL, INCIDENTAL, OR CONSEQUENTIAL DAMAGES WHETHER BASED ON CONTRACT , TORT OR ANY OTHER LEGAL THEORY AND WHETHER ADVISED OF THE POSSIBILITY OF SUCH DAMAGES.

D. Local law

To the extent that this warranty statement is inconsistent with local law, this warranty statement shall be considered modified to be consistent with such law.

Chapter 6: Appendices

Input	Description	Output	Description
1		1	
2		2	
3		3	
4		4	
5		5	
6		6	
7		7	
8		8	
9		9	
10		10	
11		11	
12		12	
13		13	
14		14	
15		15	
16		16	
17		17	
18		18	
19		19	
20		20	
21		21	
22		22	
23		23	
24		24	
25		25	
26		26	
27		27	
28		28	
29		29	
30		30	
31		31	
32		32	

SmartAVI, Inc.
2840 N. Naomi Ave.
Burbank, CA 91504
Tel (818) 565-0011 Fax (818) 565-0020
Email: info@smartavi.com